

## Simultaneous High Speed Inspection for Both Sides of PCB Automated Optical Inspection System **BF-Tristar II**

### Simultaneous Inspection for Both Sides of a PCB

BF-Tristar II is the automated optical inspection system for inspecting both sides of double-sided PCB at once. It is equipped with two cameras for scanning each side of a PCB and has the Saki's unique alternate scanning system. It also has 30 mm clearance at the both sides of a PCB. BF-Tristar II is suitable for inspections on the final process after the component assembly.

### Reducing the Inspection Process

BF-Tristar II can inspect both sides of a PCB in one scanning. With this feature, it only needs the one machine while others need two for inspecting double-sided PCBs and enables space-saving.

### Suitable for Inspections on the Final Process

BF-Tristar II can easily inspect defections on a top side of a PCB even after the SMT process of a bottom side. BF-Tristar II is suitable for inspections on the final process.

### High Resolution Imaging System

With 10 μm resolution, BF-Tristar II provides accurate and stable inspection of 01005 (0402) chips. Newly developed color capturing system takes only 8 seconds to scan M-size boards [250 mm × 330 mm].

### Advantage of Line Scan Visual Inspection

Extra components on a PCB can be detected only by setting up one inspection window on the whole board. It is realized by the advantage of line scan method.



### Coaxial Overhead Light

Soldering condition is inspected by illuminant irradiation of coaxial overhead lighting. Inspection is not affected by shadowing by neighboring tall components, therefore same library is available at any location on the board.

### New Interface

Renewed user interface makes it easier to set up inspection data by using pre-installed Saki standard library. The optional new function KPK, that detects difference between a surface of a PCB and component, simplifies to detect missing components. This realizes time reduction for inspection data making at launching production.

### Real-time Defection Management and Analysis

With the real-time SPC display function, BF-Tristar II provides the real-time production management with more efficient productivity and quality. It also provides solutions for problems in defection managements, analysis, and manufacturing processes in combination with extensive optional systems (BF-Editor/BF-RP1/BF-View/BF-Monitor).



## Dimensions

### Front View

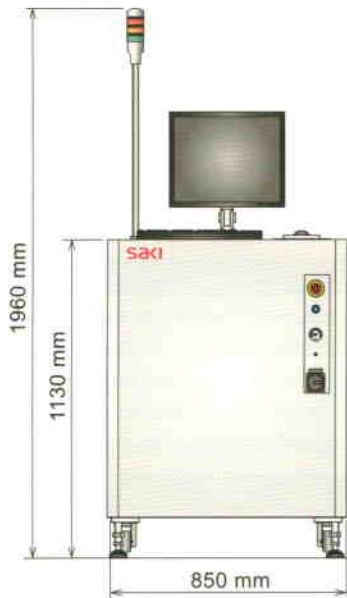

### Side View

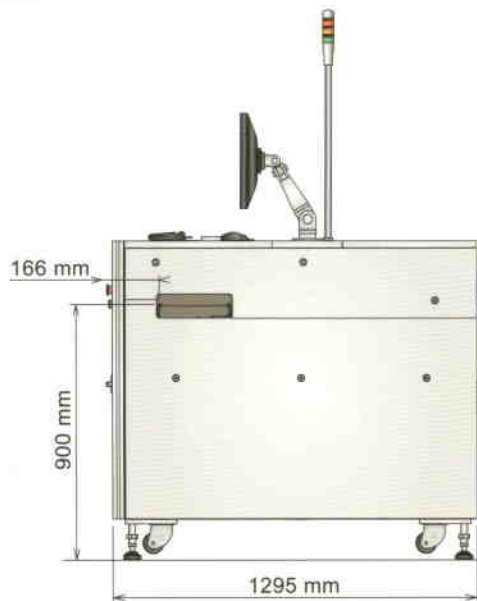

## System Specifications

Model	BF-Tristar II
Resolution	10µm
Board Size	50×60 - 250×330mm, 2×2.4 - 10×13in.
Board Thickness	0.6 - 3.2mm, 24 - 126mils
Board Warp	+/-1mm, 40mils
PCB Clearance	Top: 30mm, 1.18in. Bottom: 30mm, 1.18in.
Rotated Component Support	Available for 0 - 359°rotation (unit of 1°)
Inspection Categories	Presence/Absence, Misalignment, Tombstone, Reverse, Polarity, Bridge, Foreign material, Absence of solder, Insufficient solder, Lifted lead, Lifted Chip, and Fillet defect. Each defect name can be changed freely by system function.
Tact Time*1 *2	Approx. 21sec. (250x330mm)
Image Scanning Time*1	Approx. 8sec. (250x330mm)
Camera (Image Processing)	Line color CCD camera
Lighting	LED lighting system
Transfer Conveyor Method	Flat belt transfer
Transfer Conveyor Height	900+/-20mm, 36+/-0.8in
Transfer Conveyor Width Adjustment	Automatic
Operating System	Windows 7 English Version
Optional System	BF-Editor / BF-RP1 / BF-Monitor / BF-View

\*1 If PCB size is smaller than 250x330mm, Image scanning time will be shorter than this values.  
\*2 Including Image Scanning Time.

## Installation Specifications

Electric Power Requirement	Single Phase ~100 - 120V / 200 - 240V +/-10%, 50/60Hz, 900VA
Air Requirement	0.5MPa, 5L/min (ANR), 73PSI, 0.18CFM
Usage Environment	15°C(59F) - 30°C(86F) / 15 - 80% RH (Non-condensing)
Noise Level	58.3dB (Tentative)
Dimensions W x D x H	850 × 1295 × 1130mm, 33.5 × 51 × 45.5in.
Weight	Approx. 500kg, 1102lbs

**saki** Saki Corporation

### Headquarters

Ogawa Building, 4-14-7, Nakanobu,  
Shinagawa-ku, Tokyo, Japan, 142-0053  
TEL: +81-3-5788-6280 FAX: +81-3-5788-6295  
E-mail: sakiCorp@sakicorp.com

**Global Network**  
<http://www.sakicorp.com>

**AssyS**  
Convincing Technologies

Pumpwerkstrasse 23 • CH - 8105 Regensdorf, Switzerland  
Phone +41 44 840 58 58 • Telefax +41 44 840 58 64  
e-mail: mail@assys.ch • www.assys.ch